



pro-line



# SOUS VIDE COOKER

TEMPERATE CONTROLLED  
PRECISE VACUUM  
SEALED COOKING

**SV-9L**  
**User Manual**





## **Congratulations on your purchase of a Pro-line Sous Vide Cooker.**

---

**Note:** Please read through the instructions carefully before using or installing the product and ensure that the manual is kept in a safe place for future reference.

**The system must be properly installed and located in accordance with the installation instructions before it is used.**

**During the set up of this product if you have any questions / comments / issues DO NOT RETURN TO STORE.  
FOR SERVICE AND TECHNICAL ADVICE VISIT [WWW.PROLINEAUSTRALIA.COM.AU/CONTACT](http://WWW.PROLINEAUSTRALIA.COM.AU/CONTACT)**

---

Pro-line Australia  
PO Box 4187  
Norwood South LPO  
South Australia 5067

Email: [info@prolineaustralia.com.au](mailto:info@prolineaustralia.com.au)

Web: [www.prolineaustralia.com.au](http://www.prolineaustralia.com.au)

Find us

 [/prolineaustralia](https://www.facebook.com/prolineaustralia)

 [/proline\\_australia](https://www.instagram.com/proline_australia)



Electrical Requirements:

Australia / New Zealand 220-240V 50/60Hz

Due to manufacturing alterations product may vary slightly from that pictured.

## **OPERATION CONDITIONS & SAFETY PRECAUTIONS**

- All components need to be installed in accordance with the user manual instructions for correct performance of unit.

### **READ ALL INSTRUCTIONS CAREFULLY BEFORE OPERATION OF THE UNIT**

- This appliance should be used in conjunction with a safety switch.
- This appliance is not intended for use by persons (including children) with reduced physical, sensory or mental capabilities, or lack of experience and knowledge, unless they have been given supervision or instruction concerning use of the appliance by a person responsible for their safety.
- Do not operate appliance with a damage cord or plug or after the appliance malfunctions, or has been damaged in any manner.
- If the cord is damaged, it must be replaced by the manufacturer, its service agent or similarly qualified persons in order to avoid a hazard.
- Children should be supervised to ensure that they do not play with the appliance.
- Do not use appliance for other than intended use.
- Do not disassemble, repair or re-form the unit, it may cause injury, fire or other malfunctions. A qualified service agent must make all service adjustments. Removing any part or attempting to service the unit will void the warranty.
- To protect against fire, electric shock and personal injury, do not immerse cord, plugs, or appliance in water or other liquid.
- Do not use this appliance outdoors. It is recommended for household, indoor use only.
- Do not let the power cord of the appliance hang over the edge of a table or bench top or touch any hot surface.
- Do not operate the unit on an inclined surface. Operate the unit on a dry, flat even surface.
- Do not place the appliance or cord on or near a hot gas, electric burner or heating appliance.
- Unplug the unit when not in use and before cleaning. Allow the unit to cool before putting in or taking out parts or emptying the water container.

## OPERATION CONDITIONS & SAFETY PRECAUTIONS

- Do not touch any metal surfaces of the unit while it is in use as they will be hot. The lid may get hot while cooking; when handling hold the lids by the two sides to avoid burn.
- Do not attempt to operate (heat) the unit without sufficient water in the container to completely cover the bottom rack and to reach the minimum (MIN) level mark on the sidewall.
- Take care not to overfill the water bath. Allow sufficient room to accommodate the volume of food pouches when added to water bath. Ensure food pouches are completely submerged. Do not fill water bath to the top.
- Be careful when lifting and removing the lid after cooking. Always tilt the lid away from you as steam is hot and can result in serious burns. Never place face over the unit.
- Extreme caution must be exercised when moving the appliance when it contains hot water or other hot liquids. Always allow water bath to cool before emptying unit.
- Use only clean water to fill the water bath container.

System Specifications	Sous Vide Cooker
Model Code	SV-9L
Product Dimensions	34 (L) x 32 (W) x 28 (H) cm
Product Weight	6kg
Power	220-240V ~ 50/60Hz, 2000W
Literage	9L

## SOUS VIDE COOKER PARTS IDENTIFICATION

1. Lid
2. Lid Handle
3. Pouch Rack
4. Basket Tray
5. Water Bath
6. Power Cord and Drain Pipe Storage Area
7. Water Drainage Switch
8. Drain Switch
9. Drain Pipe
10. Rotational Base
11. Water Outlet
12. Water Intake Filter

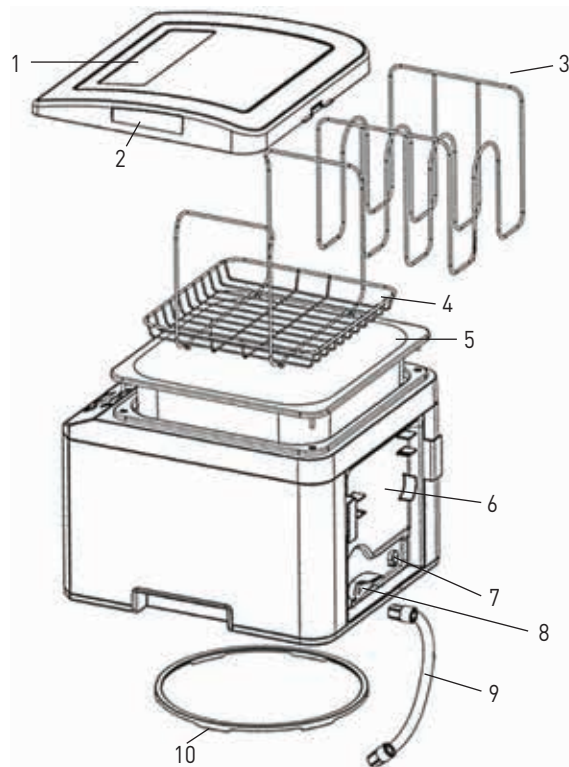
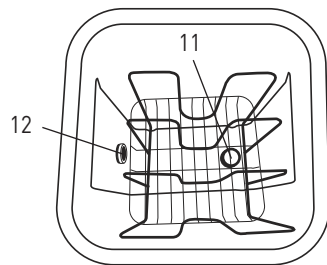

## CONTROL PANEL

1. Start/Stop
2. LED display screen
3. Set water temperature
4. Set Timer
5. Decrease value
6. Increase value
7. Power button

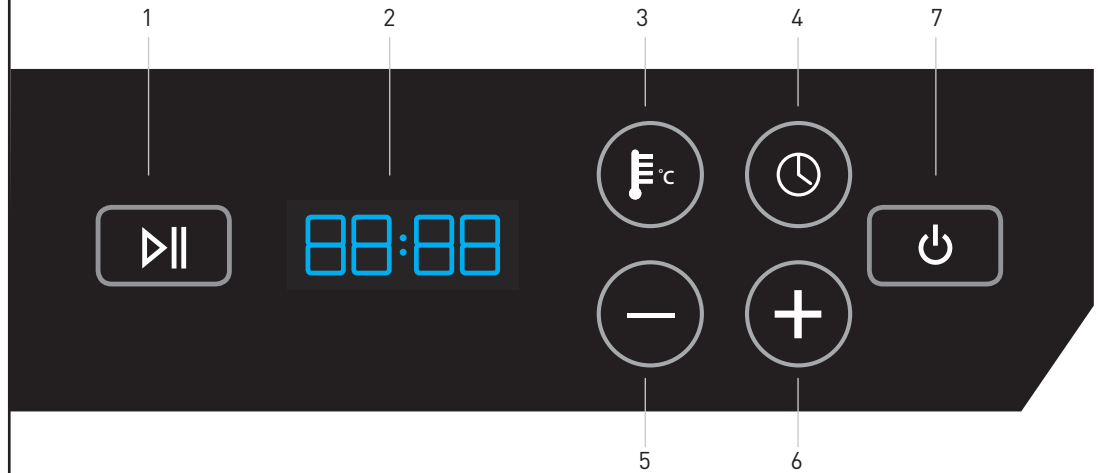

## FOOD SAFETY GUIDELINES FOR SOUS VIDE COOKING

**FOOD SAFETY CAUTION:** Pregnant women, very young children, the elderly and those with compromised immune systems should not consume foods cooked using the Sous Vide method. Food standards recommend that for safety, food should not be consumed if kept between 5°C and 55°C for longer than 4 hours.

Following the below guidelines will help to minimise the risk of food borne illness when using the Sous Vide method of cooking.

### FOOD PREPARATION

- Wash hands well before commencing any food preparation.
- Do not cross contaminate- use separate cutting boards and utensils for raw and cooked food.
- Food items used for Sous Vide cooking must be of the highest quality in freshness and thoroughly cleaned.
- Ensure that the food pouches are clean and properly vacuum sealed and have not been contaminated.
- Prepare foods to the recommended thickness in the Temperature and Time guide.

### COOKING

- Refer to the Temperature and Time guide as a guideline for cooking times and temperatures.
- Ensure that the food pouches are completely sealed before cooking commences and are still completely sealed when cooking has finished.

### STORAGE

- If the food is not intended for immediate consumption, it should be quick chilled. To safely chill, completely submerge the sealed food pouch into an ice water bath for 30 minutes to 1 hour. The food may then be frozen or refrigerated for later consumption.
- Food cooked Sous Vide can be safely kept in the refrigerator for up to 48 hours.

## TEMPERATURE AND TIME GUIDE

The tables are only meant to serve as a guideline to setting the temperatures and times for your cooking. Temperatures should be adjusted to your individual tastes and preference of doneness.

- Thickness measurement refers to thickness once the food has been vacuum sealed.
- Longer cooking times may result in an altered texture of finished foods.
- The longer the cooking time, the more tender the result.

**Tip:** Stick to the nominated cooking times initially then reduce or increase times in future to achieve your desired result.

- Cooking times are for foods starting at refrigerator temperature.

Food	Doneness	Temperature [°C]
Meat (Beef, Lamb, Pork, Veal)	Rare	54
	Medium Rare	56.5
	Medium	60
	Medium Well	65.5
	Well	68-70
<b>POULTRY</b>		
White Meat (Duck Only)	Medium Rare	56
White Meat (All Poultry)	Medium	60-63
	Well	75
Dark Meat (All Poultry)	Medium	65
	Well	75
Fish	Rare	40
	Medium Rare	50
	Medium	55
Vegetables/Fruit	-	82-85



Food	Cooking Temp (°C)	Time		Thickness
		Min	Max	
<b>BEEF &amp; LAMB</b>				
Tender Cuts (Tenderloin, Rib Eye, Sirloin, T-Bone Steak, Lamb Chops)	56 or higher	1hr	2hrs	1-2cm
		2hrs	4hrs	2-5cm
Tough Cuts (Roast, Leg of Lamb, Chuck, Shanks, Game Meats)	56 or higher	8hrs	24hrs	4-6cm
<b>PORK</b>				
Pork Belly	60 or higher	6hrs	24hrs	
Pork Chops	56 or higher	1hrs	3hrs	2-5cm
Pork Roast	60 or higher	3hrs	6hrs	5-7cm
Ribs	59	10hrs	24hrs	2-3cm
<b>POULTRY</b>				
Chicken Breast (Boneless)	64	1hr	2hr	3-5cm
Chicken Breast (Bone In)	82	2hrs	3hrs	3-5cm
Chicken Leg/Thigh	70 or higher	1hr	4hrs	3-5cm
Duck Breast	56 or higher	2hrs	8hrs	2-3cm

Food	Cooking Temp (°C)	Time		Thickness
		Min	Max	
<b>FISH &amp; SEAFOOD</b>				
Lean Fish	50	40	1.10hrs	12.5mm
Fatty Fish	50 or higher	40-50 min	1.10hrs	2.5cm
Shrimp	60	1hr	Up to 1hr	-
Prawns				
Lobster Tail				
Scallops				
<b>VEGETABLES</b>				
Root Vegetables	84	1hr	Up to 1hr	1-5cm
Tender Vegetables				

## OPERATION INSTRUCTIONS

1. Ensure the unit is placed on a properly leveled surface. Plug the unit into the appropriate power outlet.
2. Ensure that the water bath contains water before starting the machine. The water must be filled up to a level where the food pouches will be completely submerged and over the 'MIN' water level mark on the sidewall of the water bath container.

**Note:** The machine will refuse to start if water level is below the 'MIN' mark. An error signal 'E001' will appear on the display panel.

**Tip:** Fill with warm water to speed up the time needed to reach the desired water temperature.

3. Touch and hold down the Power button. The unit will beep and the LED display screen will show the current temperature of the water in the water bath.

## SET COOKING TEMPERATURE

4. Touch the Set Temperature button. The default temperature of 60°C will flash on the display screen, meaning that it is ready to be changed. Touch the – and + buttons to decrease or increase the temperature to set to your desired target temperature.

**Note:** The temperature set range is 30°C – 90°C.

**Tip:** Holding down the – or + button will change the temperature figure more quickly.

## SET COOKING TIME

5. Touch the Set Timer button, to select the time. The default time of 02:00 (2 hours) will flash on the display screen, meaning that it is ready to be changed. Touch the – and + buttons until your desired time appears in the display screen.

**Note:** The time set range is 00:00 – 99:00 hours. When set at 00:00, the machine will work continuously without time limitation.

**Tip:** Holding down the – or + button will change the time figure more quickly.

**Note:** When desired cooking time has been reached, after a few seconds the display will return to display the water bath temperature.

6. When cooking temperature and time has been set, press/touch Start button to begin heating the water temperature to the set temperature. A tone will sound as the container begins to heat.

**Note:** Ensure that the lid is on.

7. When the set temperature has been reached, the unit will beep 3-5 times. The unit is ready for the sealed food pouches.

**Note:** The unit starts to count the cooking time from this point.

8. Carefully remove the lid. With a pair of tongs gently place the sealed food pouches in the water. Ensure that the food is completely submerged with the help of the rack or tray provided. Replace the lid.

**Tip:** If cooking multiple pouches, place them vertically in the slots of the rack.

**Tip:** To view remaining time at any time during the cooking process, touch Timer button.

9. After the set cooking time has elapsed, the unit will beep indicating that the food pouches are ready to be removed.



## **CLEANING AND MAINTENANCE**

Before carrying out any maintenance or cleaning of the unit, ensure that the power to the unit is turned off and power cord is unplugged from the socket. Do not leave water sitting in the bath after use. Allow the water to cool, then drain out the water using the supplied drain pipe.

- Dry interior with a soft, clean cloth.
- Wipe the exterior of the unit with a damp cloth and polish dry.
- Do not clean unit with scourers or with any abrasive cleaning agents or solvents as these will damage the surface.
- Do not immerse the unit in water or place in a dishwasher.
- In the unlikely event of a food pouch rupturing, do not drain the water through the drain hose. Pour out the contents of the water bath out from the top of the unit. Use a soft cloth of sponge and mild soapy water to wipe away food from the container.

## **RUNNING A CLEANING CYCLE**

It is recommended to run a cleaning cycle for the unit once a month. Fill the water container with clean water to above the 'MIN' level mark and add mild soapy detergent into the water. Set temperature to 40°C and set time to 20 minutes and run the machine as normal. Once completed, allow the water to cool before draining the water using supplied drain hose.

## TROUBLE SHOOTING

BEFORE YOU CALL FOR SERVICE PLEASE REVIEW THE TROUBLE SHOOTING TIPS FIRST.

Error Code (shown on display panel)	Possible Cause	Solution
E001	<ol style="list-style-type: none"><li>1. Container is empty/Water level is low</li><li>2. Machine is not on a flat, level and stable surface</li><li>3. The unit cannot detect the presence of water in the container</li></ol>	<ol style="list-style-type: none"><li>1. Fill with water. Ensure that the water is above the 'MIN' level mark</li><li>2. Place machine on a flat even surface</li><li>3. Mix a small amount of salt into the water</li></ol>
E002	<ol style="list-style-type: none"><li>1. Food pouch is blocking the water intake</li><li>2. Food pouch has ruptured and food has blocked the water inlet.</li><li>3. Dirt has accumulated inside the water circulation system</li></ol>	<ol style="list-style-type: none"><li>1. Always use the provided Pouch Rack to position the bags</li><li>2. Run a cleaning cycle (see page 12)</li><li>3. Run a cleaning cycle (see page 12)</li></ol>



## **Your Pro-line Australian 12 Month Repair or Replacement Warranty**

Pro-line warrants this appliance to the first purchaser and subject to the stated conditions:

Warranty covers any defects in material or workmanship in the manufactured product within the first twelve months from the date of purchase.

To make a warranty claim you must visit Pro-line online at [www.prolineaustralia.com.au/warrantyclaim](http://www.prolineaustralia.com.au/warrantyclaim)

If a product is found to be faulty there is a 90 day return policy from the date of purchase. Products returned to store MUST be accompanied by a valid proof of purchase.

For warranty claims outside of 90 days from date of purchase, product will be repaired or replaced at our discretion. Repair or replacement costs of the product will be covered under warranty by Pro-line.

Goods presented for repair may be replaced by refurbished goods of the same type rather than being repaired. Refurbished parts may be used to repair the goods.

The benefits given to you by this warranty are in addition to other rights and remedies of the consumer law in relation to the goods or services to which this warranty relates.

Our goods come with guarantees that cannot be excluded under the Australian Consumer Law. You are entitled to a replacement or refund for a major failure and compensation for any other reasonably foreseeable loss or damage. You are also entitled to have the goods repaired or replaced if goods fail to be of acceptable quality and the failure does not amount to a major failure.

## **Conditions Of This Warranty:**

1. This product has been fully installed in accordance with the user manual installation instructions.
2. The warranty extends only to repairing or replacing any component that proves to be defective in material or workmanship.
3. The warranty does not cover defects occasioned by misuse, alterations, accidents, or used for other than the intended purpose.
4. The warranty does not cover damage to the product caused by accident, fire, or floods, power surges or blackouts.
5. Proof of purchase is required for warranty claims.

Please keep purchase receipt in a safe place.

**Pro-line Australia**  
**PO Box 4187**  
**Norwood South LPO**  
**South Australia 5067**

[info@prolineaustralia.com.au](mailto:info@prolineaustralia.com.au)  
[www.prolineaustralia.com.au](http://www.prolineaustralia.com.au)





Pro-line Australia  
PO Box 4187  
Norwood South LPO  
South Australia 5067

Email: [info@prolineaustralia.com.au](mailto:info@prolineaustralia.com.au)

Web: [www.prolineaustralia.com.au](http://www.prolineaustralia.com.au)

Find us

 [/prolineaustralia](https://www.facebook.com/prolineaustralia)

 [/proline\\_australia](https://www.instagram.com/proline_australia)