



pro-line™

Drink Blender

BL-121

User Manual





Congratulations on your purchase of a Pro-line Drink Blender.



Note: Please read through the instructions carefully before using or installing the product and ensure that the manual is kept in a safe place for future reference.

The system must be properly installed and located in accordance with the installation instructions before it is used.

During the set up of this product if you have any questions / comments / issues **DO NOT RETURN TO STORE.**
FOR SERVICE AND TECHNICAL ADVICE VISIT WWW.PROLINEAUSTRALIA.COM.AU/CONTACT

Pro-line Australia
PO Box 4187
Norwood South LPO
South Australia 5067

Email: info@prolineaustralia.com.au
Web: www.prolineaustralia.com.au

Find us
 [/prolineaustralia](https://www.facebook.com/prolineaustralia)
 [@proline_australia](https://www.instagram.com/proline_australia)



Electrical Requirements:
Australia / New Zealand 220-240V 50Hz
Due to manufacturing alterations product
may vary slightly from that pictured.

OPERATION CONDITIONS & SAFETY PRECAUTIONS

READ ALL INSTRUCTIONS CAREFULLY BEFORE OPERATION OF THE UNIT

- All components need to be installed in accordance with the user manual instructions for correct performance of the appliance.
- This appliance is not intended for use by persons (including children) with reduced physical, sensory or mental capabilities, or lack of experience and knowledge, unless they have been given supervision or instruction concerning use of the appliance by a person responsible for their safety.
- Appliance can be used by persons with reduced physical, sensory or mental capabilities or lack of experience and knowledge if they have been given supervisions or instruction concerning use of the appliance in a safe way and if they understand the hazards involved.
- Children should be supervised to ensure that they do not play with the appliance.
- Do not operate appliance with a damaged cord or plug or after the appliance malfunctions, or has been damaged in any manner.
- If the cord is damaged, it must be replaced by the manufacturer, its' service agent or similarly qualified persons in order to avoid a hazard.
- To protect against risk of fire, electric shock and personal injury, do not immerse cord, plugs, or Blender Base in water or other liquid.
- Unplug from outlet when not in use, before assembling or taking off parts and before cleaning.

- Do not use attachments not recommended or sold by the manufacturer as it may lead to fire, electric shock or injury.

WARNING: RISK OF INJURY: Keep hands and foreign objects out of the blending jug while the motor is running. Always switch the blender off at the wall socket and ensure the motor has stopped completely before disassembling.

IMPORTANT:

- Do not use appliance for other than intended use.
- Handle the cutting blade with care, especially during cleaning. Do not try and dismantle the blades from the blending jug, they are permanently fixed to the jug.
- Do not leave the appliance unattended when in use.
- Place the device on a level, nonslip surface suitable for the weight of the appliance.
- Do not use outdoors or on wet surfaces.
- Do not run the appliance without loading the blender jug.
- Do not run the appliance without ensuring the lid is securely in place.
- Do not put any parts into the dishwasher. NOT dishwasher safe.



SAFETY FEATURES

Your Blender has 2 safety functions. Occasionally during the use of the Blender you may find that these safety functions have caused the unit to temporarily cease working. This is completely normal and is implemented to protect the user and unit from damage.

Overheating Protection

The motor of the Blender is equipped with a temperature control device. If the motor or the blades turn too slowly due to solid food or lack of fluid there is a danger of the unit overheating. If your unit should switch off for that reason, unplug the Blender from the wall socket and move into a well-ventilated area. Allow the Blender to cool down for approximately 45 minutes, you can then recommence use.

Auto Shut Down

The maximum running time of this Blender is 10 minutes. To prevent overuse or overheating of the appliance the Blender will automatically switch off after 10 minutes running time.

Sensor for the Blender Jug

Blender is equipped with a safety sensor which detects when the blender jug has been seated onto the motor correctly. If the blender jug has not been assembled correctly you will not be able to operate the Blender. Due to safety reasons please do not attempt to bypass the sensor.

System Specifications	Pro-line Blender
Model Code	BL-121
Product Dimensions	190 (L) X 200 (W) X 410 (H) mm
Product Weight	4.4KG
Power	1200W, 220-240V ~50Hz
Blender Jug	1L volume, BPA free plastic, stainless steel blade
Max. Running Time	10 minutes

BL-121 PARTS IDENTIFICATION

1. Measuring Cup
2. Lid
3. Blender Jug
4. Blade (non-removeable)
5. Blade Mount (non-removeable)
6. Drive Coupling (non-removeable)
7. Blender Jug Mat
8. Blender Base
9. Control Panel
10. Power indicator light
11. Anti-skid rubber feet
12. Power cord

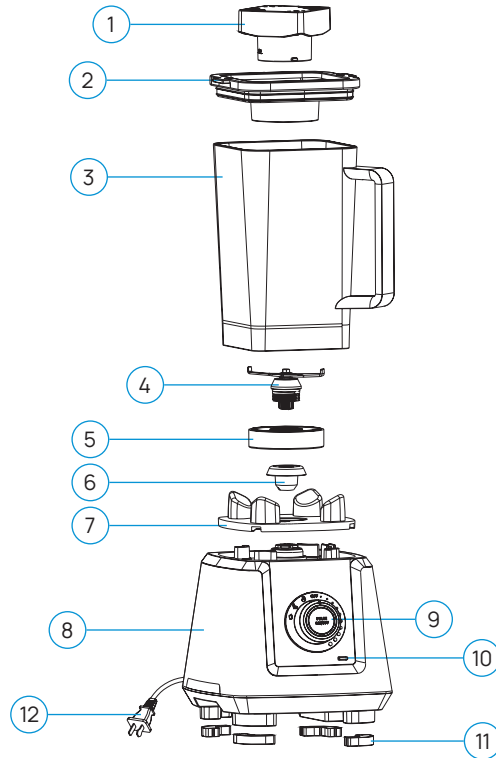

BL-121 CONTROL PANEL

1. Pre-set program icons
2. Speed Dial
3. Pulse button / ON/OFF button
4. Indicator Light
5. Power Light
6. Off/Reset position

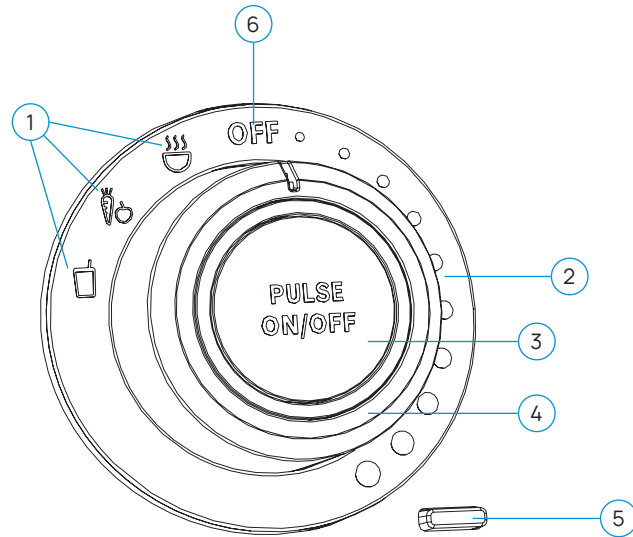

BL-121 CONTROL PANEL DESCRIPTION

Ref	Description
-----	-------------

1.	Pre-set Programs 1-3
----	-----------------------------

There are 3 Pre-set Programs (See page 9 for full details on each program).

Turn dial Anti-clockwise to the desired Program. Press On/ Off to start the program.

The Program can be stopped at any stage by pressing On/ Off.

2.	Speed
----	--------------

Turn Speed dial clockwise to gradually increase speed level. Turn Speed dial anti clockwise to reduce speed level. This Blender has 10 Speed settings.

Turn Speed Dial to OFF position to stop Blender or press Pulse/ On/ Off button.

The Blender will automatically turn off after 10 minutes.

3.	Pulse / On/Off
----	-----------------------

In Blender Ready Mode press and hold pulse to quickly increase speed to the highest level. Motor will stop when the pulse key is released.

Press On/ Off to start a Pre-set Program. Press On/ Off to stop the Program at any time.

Pressing On/ Off during use of the Speed Dial will stop the Blender.

Ref	Description
-----	-------------

4.	Indicator Light
----	------------------------

In Blender Ready Mode, Indicator Light will illuminate RED.

During operation Indicator Light will illuminate WHITE.

After 3 minutes of inactivity the Blender will enter Energy Saving Mode and the Indicator Light will go out. Press any key to exit Energy Saving Mode.

If the Indicator Light flashes red return the dial to the OFF position to reset the Blender.

5.	Power Light
----	--------------------

Power Light will illuminate RED when there is power to the Blender.

OFF Turning the speed dial OFF position will stop the blender and reset it to ready mode.



OPERATING INSTRUCTIONS

- Do not insert hands or items into the jug while the blender is in use.
- Do not operate appliance with wet hands as it may cause an electric shock.
- Do not operate appliance prior to inserting ingredients.
- Do not operate appliance without the lid.
- Do not operate for more than 10 minutes at a time.

IMPORTANT: To protect the motor and provide you with a long lasting machine, the Blender has an auto shut down feature. If the components are not installed correctly the system will not operate. If the motor overheats due to extended use of the product the machine will automatically shut down. This is normal and prevents damage to your Blender. Refer to safety features on page 4.

1. Ensure the Blender Base is on a flat, level surface. Assemble the Blender Jug onto the Blender Base, ensuring that the jug is seated correctly.

NOTE: If the Blender Jug is not seated onto the Blender base properly the Blender will not start.

2. Plug in the Blender and turn on at the wall socket. The Power Light and Indicator Light will light up RED. The Blender is now in Ready Mode.

USING IN MANUAL MODE

Before Blending always ensure the Blender Jug is installed correctly, the Lid is securely on and there are ingredients in the Blender Jug ready to Blend.

1. Directly turning the speed dial clockwise will immediately start the Blender at speed 1. Continue to turn the speed dial clockwise to gradually increase speed from 1 to 10. During operation the indicator light will turn WHITE.
2. To reduce the speed, turn the speed dial anti-clockwise.
3. To stop the Blender turn dial back to the OFF position.
4. Ensure the indicator light turns RED before removing the Blender Jug.



NOTE: The Blender will automatically turn off after 10 minutes.

USING A PROGRAM

Before Blending always ensure the Blender Jug is installed correctly, the Lid is securely on and there are ingredients in the Blender Jug ready to Blend.

1. There are 3 Pre-set Programs. To select rotate the Speed Dial anti-clockwise to the desired Program.
2. Press Pulse/ On/ Off to start the program. During operation the indicator light will turn WHITE.
3. When the Program is complete the indicator light will turn RED. Wait until the indicator light turns RED before removing the Blender Jug.
4. If required, the program can be stopped at any time by pressing Pulse/ On/ Off button.
5. After the program has finished return the Speed Dial to the OFF position.

3 PRE-SET PROGRAMS

Symbol	Program	Pre-set Program Description	Description
	Soup	Increases to Speed 7 in 7s Increases to Speed 10 in 3s, then keeps at this speed until finished. Total Run Time: 8min	Good for creamy vegetable soup. CAUTION: After this program 1L of soup will be boiling hot. Ensure lid and measuring cup are securely attached to avoid scalding due to splashes of hot liquid.
	Vegetable/ Fruit Smoothies	Speed 10 for 30s, Stop 2s Speed 6 for 10s, Stop 2s Speed 10 for 60s, Stop 2s Speed 6 for 10 seconds. Total Run Time: 1min, 56s	Good for general vegetable/ fruit smoothies to totally emulsify the ingredients into a fine and smooth texture.
	Cocktail/ Liquid Drink	Soft start to Speed 10 for 8s, Stop 2s. Repeats this cycle until finished. Total Run Time: 30s	This shorter program is good for various cocktails and liquid drinks.



OPERATING TIPS

The Pro-line Blender is a great addition to any kitchen, allowing simple and quick preparation of drinks, purees, sauces and soups. The more familiar you are with your Pro-line Blender the easier preparing dishes will be. Below are some tips that will help you get started.

- For best results pour liquids and soft ingredients into the blender jug first followed by the harder ingredients such as ice cubes, leafy greens.
- When making sauces, stuffings or processing nuts, put in between 2 and 3 cups of ingredients (as per the markings on the Blender Jug). The amount needs to be neither too large or too small.
- Keep the blending time below 2 minutes to prevent any burning smell due to overheating. Too large a quantity of ingredients may lead to overloading and overheating of the motor. In this case, wait until the motor temperature falls before operating again.
- When blending thick or sticky ingredients always start at low speed before increasing to high speed. If there is no rotation of the blades disconnect the power and stir the contents.
- Do not overload the unit nor add too little ingredients.
- To prevent spillage, do not put liquid in blender jug exceeding the MAX line.
- To avoid leaks place the lid firmly on the Blending Jug.
- Blender Jug components come pre-assembled and should not be disassembled.
- The Blender cannot be operated if:
 - The Blender Jug is not correctly seated on the base,
 - The Speed Dial is turned to variable speed before the jug is positioned onto the base,
 - The Blender Jug is removed during operation and put back again.

To resolve the above and reset the Blender, turn the Speed Dial back to the OFF position and ensure the Blender Jug is correctly positioned on the Base.

LID / MEASURING CUP

The lid comes with a detachable 90ml measuring cup. The measuring cup can be removed during operation to add additional ingredients.

WARNING: RISK OF INJURY. Do not remove the measuring cup during the SOUP Program to avoid scalding due to splashes of hot liquid.

To remove measuring cup twist cup anti-clockwise a quarter turn and then lift upwards.

To insert measuring cup align the two tabs on the bottom with the slots on the lid, push measuring cup down and then twist clockwise until it locks.

Ensure that the lid is always securely pushed onto the Blender Jug before use.



CLEANING AND MAINTENANCE

This section provides important information for cleaning and maintenance of your Pro-line Blender. Please note the following safety guidelines before and during cleaning:

WARNING: RISK OF INJURY: The blades are SHARP! Care must be taken to avoid personal injury when cleaning

- Always switch off the appliance and remove the power plug from the socket before cleaning
- Do not immerse appliance in water or any other liquid.
- The Blender Jug is NOT suitable for the dishwasher and should NOT be fully immersed in water.
- Do not try and dismantle the blades from the container, they are permanently fixed to the Jug.

To clean Blender Jug

Fill the Blender Jug to no more than the maximum level with warm water and add a drop of mild detergent. Place onto the Blender Base. Ensure the lid is securely on and use the Pulse mode until the blender and

blade are clean. Replace the water and repeat if necessary. Pour water out and dry with a soft cloth. NEVER immerse the whole jug in water.

IMPORTANT: Always ensure the base of the jug is free from water as it may cause the bearing to rust and affect the performance of the blender.

The lid and measuring cup can be disassembled and washed in a sink of warm water, dry thoroughly before use.

To clean the Blender Base

WARNING: Do NOT immerse the Blender base in water or any other liquid.

Clean the Blender Base with a soft damp cloth only.

NOTE: If water or liquid is left on the Blender Blade, it may cause discolouration to occur. This does not affect the structure or strength of the blade.

TROUBLE SHOOTING: BEFORE YOU EMAIL FOR SERVICE PLEASE REVIEW THE TROUBLE SHOOTING TIPS FIRST.

Problem	Possible Cause	Solution
No power to blender.	Appliance not plugged in/switched on.	Check the Blender is plugged in and the on/ off switch (located on right, underside of the blender base) is turned on.
	Incorrect assembly.	If the Blender Jug is not properly installed the unit will not turn on. Reinstall the Jug, the unit will beep when the jug is correctly installed.
Motor has stopped.	Ingredients stuck in blades.	If a large piece of ingredient is stuck at the bottom of the machine, switch the appliance OFF and remove blockage. WARNING: Blades are SHARP. Take care when removing blockages.
	Lack of fluid.	There is a danger of the unit overheating if there is a lack of fluid. Unplug the Blender from the wall socket and move into a well-ventilated area. Allow the Blender to cool down for approximately 45 minutes, you can then recommence use.
	Overuse of product has caused motor to shutdown as a safety precaution.	Unplug the Blender from the wall socket and move into a well-ventilated area. Allow the Blender to cool down for approximately 45 minutes, you can then recommence use.
Leaking.	Blender Jug has been overfilled.	Make sure the level of ingredients does not exceed the max fill line.
	Lid is not installed correctly.	Ensure the lid is seated correctly.



Your Pro-line Australian Commercial Repair or Replacement Warranty

Pro-line warrants this appliance for 24 months on electrical parts and 12 months on Jugs and Blades.

Pro-line warrants this appliance to the first purchaser and subject to the stated conditions:

- The term "Commercial" when referring to our warranty is defined as use in a commercial setting or using the product on a commercial scale regardless of where the product is stored.

Warranty covers any defects in material or workmanship in the manufactured product within the first 24 months for electrical parts and 12 months for Jugs and Blades of a Commercial warranty, from the date of purchase.

To make a warranty claim you must visit Pro-line online at www.prolineaustralia.com.au/warrantyclaim

If a product is found to be faulty there is a 90 day return policy from the date of purchase. Products returned to store **MUST** be accompanied by a valid proof of purchase.

For warranty claims outside of 90 days from date of purchase, product will be repaired or replaced at our discretion. Repair or replacement costs of the product will be covered under warranty by Pro-line.

Goods presented for repair may be replaced by refurbished goods of the same type rather than being repaired. Refurbished parts may be used to repair the goods.

The benefits given to you by this warranty are in addition to other rights and remedies of the consumer law in relation to the goods or services to which this warranty relates.

Our goods come with guarantees that cannot be excluded under the Australian Consumer Law. You are entitled to a replacement or refund for a major failure and compensation for any other reasonably foreseeable loss or damage. You are also entitled to have the goods repaired or replaced if goods fail to be of acceptable quality and the failure does not amount to a major failure.

Conditions Of This Warranty:

1. This product has been fully installed in accordance with the user manual installation instructions.
2. The warranty extends only to repairing or replacing any component that proves to be defective in material or workmanship.
3. The warranty does not cover defects occasioned by misuse, alterations, accidents, or used for other than the intended purpose.
4. The warranty does not cover damage to the product caused by accident, fire, or floods, power surges or blackouts.
5. The warranty does not cover consumables.
6. Proof of purchase is required for warranty claims.

Please keep purchase receipt in a safe place.

Pro-line Australia

PO Box 4187

Norwood South LPO

South Australia 5067

info@prolineaustralia.com.au



www.prolineaustralia.com.au



Pro-line Australia
PO Box 4187
Norwood South LPO
South Australia 5067

Email: info@prolineaustralia.com.au
Web: www.prolineaustralia.com.au

Find us

 [/prolineaustralia](https://www.facebook.com/prolineaustralia)
 [@/proline_australia](https://twitter.com/proline_australia)